



HOLIDAY 350SE & 400SE TRAILER TENT

Thank you for purchasing the Holiday Trailer Tent from SunnCamp.

Before erecting this tent, carefully read and understand these instructions. If there is anything you do not understand, contact your retailer for advice.

By following the instructions on erecting, dismantling, packing and storing the tent you will enjoy many years of trouble free camping.

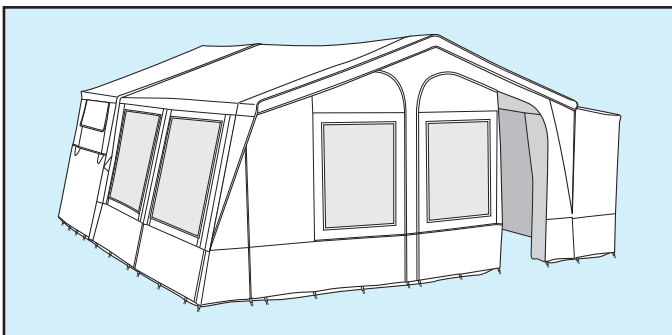

INSURANCE

We highly recommend that your trailer tent is insured against theft and storm or accidental damage. Storm or accidental damage is not covered under the warranty.

IMPORTANT- CHECK YOUR EQUIPMENT

Before going away with your trailer tent, ensure that you are familiar with the pitching of the trailer tent and that all parts are present. You should familiarise yourself with the trailer tent including any limitations it may have for your particular use. A trailer tent is a portable structure, which, under most circumstances, will provide comfortable shelter against the elements. There are however extremes of weather for which allowance should be made. DON'T BLAME THE TRAILER TENT.

SUITABILITY

Position: Sheltered Lowland/Valley

Weather: Fair/Moderate

WEATHERING

Before a cotton trailer tent is used for the first time, it is important that the tent is weathered. Pitch the trailer tent when rain is expected, or alternatively when you have access to a garden hose with a spray setting, and allow to get thoroughly wet and then fully dry out. When the cotton of the tent becomes wet for the first time the weave of the cotton will close when allowed to dry under tension. There is no predetermined time for weathering so do not be surprised if

there is a small amount of leakage through the canvas and seams the first few times it rains.

COTTON

The outer and inner trailer tent is made of cotton. Cotton is a natural fibre and may contain some imperfections. These should not be mistaken for faults and will not affect the performance of your trailer tent.

PITCHING THE CABIN

Before pitching your trailer tent it is essential that you read the following:

CHOOSING A SITE

Try to choose a site that is relatively flat. Avoid sites where the land may flood or that water will run down. DO NOT camp directly under trees but a hedge or wall may provide shelter against wind. AVOID areas with heavy pollution and where crop spraying may be in progress.

1. On the chosen site it will be necessary to make the trailer as level as possible and to take the weight of the trailer off the wheels to provide a stable cabin.
2. Using the jockey wheel adjust the height of the trailer so that the front end is about 5 cm lower than level. Drop the rear legs of the trailer onto the supplied jack pads and tighten locking screws.
3. Using the jockey wheel, raise the front of the trailer until the unit is level. Drop front legs of the trailer onto jack pads and tighten. Lower jockey wheel slightly to allow the trailers weight to be borne by the legs.
4. Unclip and remove the cover.
5. Disconnect 7 pin plug under the trailer. Release kitchen legs until they are close to but not touching the ground. Release side catches and lift off kitchen unit (this will require at least two persons). Loosen the locking screws for the kitchen support bars and push support bars back into trailer body. Adjust the kitchen legs to a suitable height and ensure that the locking screws are secure. If not required the kitchen can be stored under a trailer bed board.

Swing over the near side cabin roof frames. The canvas will automatically follow.

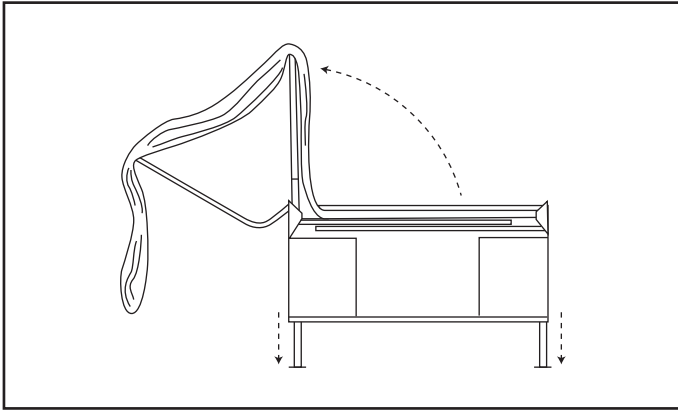

Repeat for the offside and then swing the central roof sections up to the apex and connect the two sections front and rear.

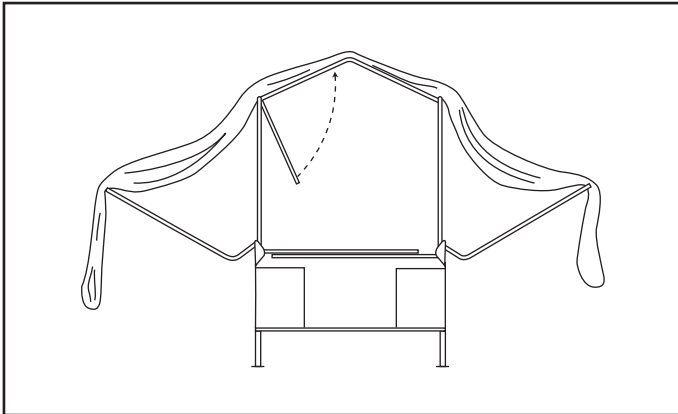

Extend the cabin poles to their maximum length using the spring buttons and fold over the left and right hand beds in that order. Adjust the legs to provide level beds.

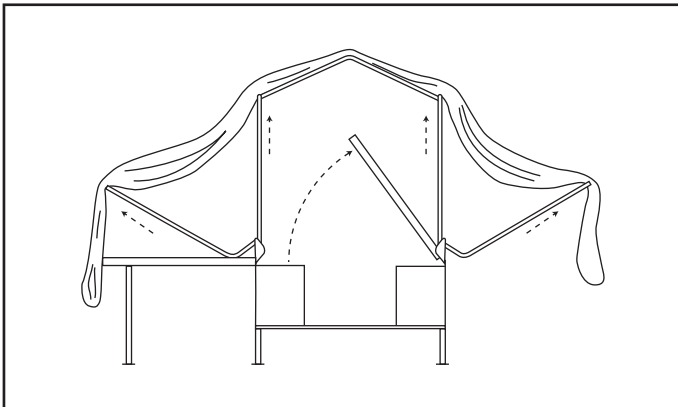

Undo retaining straps that secure inner tent and mattress to the bed board and clip inner tent onto the frame using plastic clips. (All Holiday trailer tents are delivered without the inner tents or mattress covers fitted. Once fitted however the inner tents can remain in situ and need only be unclipped from the frame for folding)

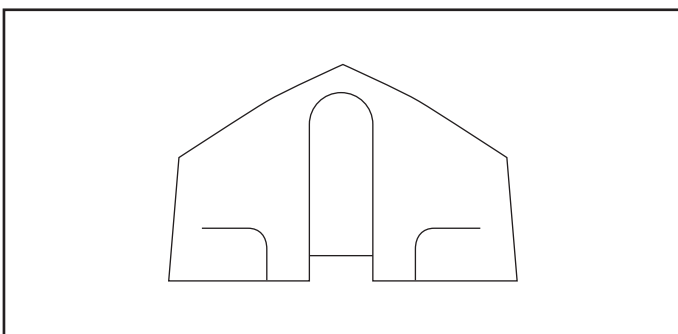

Pull down cabin canvas and adjust the frame downwards so that the pegging points comfortably reach the ground.

PITCHING THE AWNING

1. Zip the awning canvas onto cabin using the two heavy duty zips and ensuring the zip covers are in place. Fold the awning canvas over the top of the cabin to expose the cabin's front wall.
2. Study the frame diagram supplied with your trailer tent and layout frame in situ. Starting with the three extension roof poles that attach to the cabin frame (no. 7) build the awning frame but do not attach the three short stub canopy poles at the front.
3. Pull canvas back over the awning frame ensuring that the front of the frame locates through the three cutaways in the front of the awning canvas. Attach stub canopy poles to the frame and pull canvas pockets over the poles. Please note that with the Holiday 400SE initially only build the first section of the frame before pulling the canvas over, the frame needs to go through the canvas prior to the front section of the frame being built.
4. Extend the three adjustable roof poles inside to bring the canvas under tension, then lock in place by turning the lock screw clockwise.

PEGGING THE UNIT

1. Peg the trailer tent in the following sequence:
 - a) Close all doors and other zips
 - b) First, peg one rear corner. Peg in line with the seam inserting the peg at an angle of 45°.
 - c) Go to other rear corner and stretch the rear of the trailer tent. The canvas will become taut without any creases. Once again, peg in line with the seam as before.
 - d) Go to the front corners and repeat this procedure but this time pulling the front leg forward and out with the canvas, making sure that there are as few creases as possible in front and side of the trailer tent canvas. ANY DOORS OR EXTERIOR ZIPS MUST BE CLOSED TO THE BOTTOM TO SUCCESSFULLY PEG YOUR TRAILER TENT.
 - e) Working from the rear centre pegging points, continue to peg your trailer tent. The canvas should always be taut with no creases and the pegs should all be in line with each other. It is not necessary to pull the canvas too far out - a straight line is preferable from corner to corner. Cross peg all doorways to avoid excess tension on zips and to prevent them from working their way open.
 - f) When you are finished, the trailer tent canvas should be taut on the frame with no "flapping canvas". Each side should be pegged neatly and in as straight a line as possible. Where possible, pegs should be in line with the seam.

PLEASE TAKE EXTREME CARE WHEN PITCHING YOUR TRAILER TENT IN WINDY CONDITIONS AND ENSURE THAT YOU HAVE ADEQUATE HELP.

INNER TENTS

It will be necessary at first use to fit the inner tents. This is a simple procedure and involves inserting the mattress into the base of the inner tent and clipping the top of the inner to the cabin frame. The seat cushions also fit within the inner tent to enlarge the bed. Once fitted the inner tents need only be unclipped from the frame before folding. Then, along with the mattresses are secured when folding by the retaining straps. DO NOT PUT TOO MUCH STRESS ONTO THE INNER TENT SUSPENSION POINTS.

GUYING THE TRAILER TENT

The trailer tent should be guyed using the guying points supplied on the trailer tent. Please note that guying is only reliable if the correct tent peg is used and the peg is inserted correctly (see following section).

PEGS

General purpose pegs are supplied with this trailer tent and are suitable in many instances. There are many types of pegs available and it is up to you to choose the correct peg for the job. Your sunncamp dealer will be able to give you advice.

MUDWALL

The mudwall is located on the inside of the trailer tent awning and a groundsheet can be laid on top of it in the living area.

CURTAINS

These should be clipped on the curtain track and retained by the curtain tape. Pack curtains separately if they are wet or even slightly damp to avoid any possibility of colour transfer.

TAKING YOUR TRAILER TENT DOWN

If possible, this should be done when the trailer tent is completely dry. Reverse the erection procedure remembering to unclip the inner tents before folding. Take care to fold beds and cabin frame in the correct order - failure to do this will result in damage.

PLEASE TAKE EXTREME CARE WHEN TAKING DOWN YOUR TRAILER TENT IN WINDY CONDITIONS. DO NOT TRY TO TAKE YOUR TRAILER TENT DOWN ON YOUR OWN - GET SOMEBODY TO HELP YOU.

CARE OF YOUR TRAILER TENT

CANVAS

This should always be packed away and stored completely dry. If you have to take your trailer tent down wet then, at the first possible opportunity, PITCH THE TRAILER TENT TO DRY IT. DO NOT LEAVE IT PACKED WET. Damp storage will cause mildew and may result in colour run. **IMPORTANT:** If your trailer tent is wet do not pack curtains with canvas as this may result in colour transfer.

NEVER clean your trailer tent with anything other than pure water and a soft brush. NEVER USE detergents, petrol, turps etc.

It may be necessary to re-proof your canvas at sometime. The time will vary according to the amount of use and the prevailing conditions. There are many good waterproofing agents available - see your sunncamp dealer for details. NEVER use aerosols or other chemicals close to your trailer tent canvas.

FRAME

Take care not to put excess strain on your frame. When erecting or dismantling, make sure that you do not over-extend the spring links. Should this happen, your sunncamp dealer will be able to supply replacements. Should your frame require any lubrication of moving parts we advise the use of a silicon spray, DO NOT USE ANY OIL BASED PRODUCT!

KITCHEN

Ensure that the legs of the kitchen are securely tightened. The front panel of the kitchen should be removed by lifting upwards with the kitchen lid/s open. The Holiday 350 and 400 have a split kitchen top. Only use the gas cooker with both lids open.

GAS CONNECTION

The double burner & grill are designed to operate from either butane or propane using regulators of the following operating pressures:

Butane - 28 mbar

Propane - 37 mbar

The kitchen has a push on gas hose fitting and the gas hose (not supplied) should be fastened using a suitable hose clip. Connect and operate the regulator according to the manufacturer's instructions.

FIRE PRECAUTIONS - REMEMBER, YOUR TRAILER TENT CAN BURN. CAMP SAFETY - FOLLOW THESE COMMON SENSE RULES

- When siting, ensure a minimum distance of 6 metres is between trailer tents
- Do not place cooking, heating or lighting appliances near the sides or the roof
- Always observe the safety instructions for the appliances
- Keep exits clear
- Make sure that you learn the fire arrangements on the site
- Never allow children to play near lighted appliances

TRAILER

The sunncamp trailer is designed to be as maintenance free as possible. The chassis and trailer frame are galvanised to provide superb corrosion resistance. It is however quite normal for the finish to dull - this will not affect the performance or durability of the trailer.

SERVICING

The following service procedures should be carried out at either the recommend mileage interval or according to time (whichever occurs first)

Pre Delivery

- Check all wheel nuts
- Check ball hitch connection
- Check road lighting
- Check brake operation (if fitted)

20 Miles

- Check all wheel nuts

Every 500 Miles or 3 Months and Before Each Journey

- Check all wheel nuts
- Check condition of tyres
- Lubricate jockey wheel
- Lubricate tow hitch
- Check condition of safety cable
- Check road light operation

TYRES/WHEELS

This trailer is fitted with 145 x 10 wheels and tyres. It is essential for correct operation that the tyre pressures are checked when cold. Tyre pressures will be found on the trailer chassis plate. We recommend that a spare wheel is carried at all times (optional at extra cost).

LOADING

Check the chassis plate for the actual weights for your trailer. Do not exceed the MGW and ensure that the load is equally distributed on the trailer. This trailer is designed to be nose heavy so improving the towing characteristics. Check the nose weight against the recommended nose weight for your towing vehicle. Ensure that the trailer is not loaded too heavily at the rear.

STORAGE

During long periods of inactivity and during the winter months, it is essential that all canvas parts, mattresses, curtains, etc. are removed from the trailer and stored in a warm dry environment. Failure to do this may result in mildew damage to these parts. If these parts are left attached to the trailer we recommend frequent checks and airing of the unit to prevent damage from mildew. The cabin canvas is easily removed from the cabin frame.

If possible garage your trailer body whenever possible. If stored outside protect the unit, especially the transit cover. Beware of condensation forming either under any protective cover or under the transit cover itself.

If possible, raise the tyres off the ground to prevent damage to tyres but do not support the weight on the corner legs. Protect the 7 pin plugs and socket with a liberal coating of petroleum jelly.

CLEANING

Cabin Canvas/Awning Canvas

Clean only with pure water and a soft cloth or brush

Inner Tents/covers/curtains/linings

Dry clean only

Trailer

Non abrasive automotive cleaners

Stainless steel kitchen unit

Non abrasive household cleaner

SPARE PARTS

Should you damage or lose any parts of your sunncamp trailer tent, spares are available from your sunncamp dealer. In case of difficulty contact sunncamp direct. **IMPORTANT** For all warranty claims please contact your sunncamp dealer - do not contact sunncamp directly as all warranty claims must be processed through your dealer.

Warranty:

This Tent is covered by a 12 month warranty. The Company undertakes to replace or repair, free of charge, any defect which the Company considers to be due to faulty workmanship or material within 12 months of the purchase date, except for:

- Defects arising from neglect, misuse or unauthorised modifications.
- Damage caused by storm, abuse, misuse, dropping or other similar damage caused by or as a result of failure to follow storage or erection instructions.
- Unauthorised alterations, additions or repairs.
- Transportation or shipment costs to and from the Manufacturer or their recognised agents, for repair or assessment against a warranty claim.
- Damage caused due to UV degradation.
- Materials and/or labour costs to renew, repair or replace components due to fair wear and tear or condensation.
- Tents used on permanent sites or displays.

THIS DOES NOT AFFECT YOUR STATUTORY RIGHTS.

The Manufacturer and/or their recognised agents, directors, employees or insurers will not be held liable for consequential or other damages, losses or expenses in connection with or by reason of or the inability to use the tent for any purpose.

NOTE; Any claim(s) arising due to missing parts or faulty goods **MUST** be made before use. The manufacturer will not be responsible for any claims regarding missing parts or faulty items where the product has not been checked by the user prior to use.